

A constant-volume gas pump for gas electrodes

C. CONTRERAS-ORTEGA*, L. SILVESTER†, P. A. ROCK

Department of Chemistry, University of California, Davis, California 95616, USA

Received 19 September 1979

A pump suitable for use with gas electrodes, in which recirculation of the gas is necessary, is described. The system to which the cell with the gas electrode and the pump are connected does not change its volume when the pump is in operation. The pump works as follows: an embolus, consisting of a Teflon-coated magnetic stirring bar, placed inside a glass tube having an internal diameter slightly larger than the diameter of the bar, is moved from the outside with a permanent magnet, which in turn is moved horizontally along the tube by means of a mechanical assembly driven by an electric motor. The motion of the embolus is accompanied by the closing and opening of glass valves which allow the gas to circulate in the desired direction. The pump, used in conjunction with a vacuum line, operates from pressures as low as 60 Torr to above atmospheric pressure. The operation of the pump is unaffected by organic gases and most inorganic gases.

1. Introduction

When a gas electrode is used in an electrochemical cell it is not always convenient, and sometimes not even acceptable, to allow the gas to escape to the atmosphere after it has bubbled through the cell solution. In closed cell systems, or with cells that are operated at pressures significantly different from atmospheric, or when the gas is expensive (e.g. D₂), the recirculation of the gas in a closed cell system may be required. Silvester and Rock [1] have described a pump for gas recirculation that has several features that are desirable in electrochemical measurements with gas electrodes, namely, automatic operation, small displacements, continuous delivery of gas, wide range of working pressures, the absence of an upper electrical contact (a feature that reduces the chance of a spark-initiated explosion in a gas mixture), it can be used in conjunction with a vacuum line, and is unaffected by organic vapours and most inorganic vapours. Here we report a pump that has all of the features of the above pump, and, in addition, introduces some improvements of significance, namely: its mechanical and electrical parts are comparatively much simpler, it is more compact,

its functioning is simpler, it works from pressures as low as 60 Torr up to pressures higher than atmospheric, and it is not necessary to make periodic adjustments for its correct continuous functioning. Finally, the system to which the cell with the gas electrode and the pump are connected does not change its volume during operation.

2. Experimental

Fig. 1 shows a diagram of the pump. The pump works as follows: the magnetic stirring bar, a, placed inside a gas tube having an internal diameter slightly larger than the bar, is moved from the outside with a permanent magnet, b, which in turn is moved horizontally along the tube by means of a mechanical assembly driven by a small electrical motor. When the embolus is moved to the right in Fig. 1, vacuum is created behind it and a pressure increment ahead of it. Because of this pressure difference, valve d closes down and the valve c opens up, thus allowing the gas to circulate, through the electrochemical cell and back to the pump in the arrow directions. In this way the space in front of the embolus is filled with gas. When the embolus reaches its maximum

* Present address: Depto. de Química, Centro de Investigación y de Estudios Avanzados del Instituto Politécnico Nacional, A.P. 14-740, México 14, DF.

† Present address: Department of Materials Science, University of California, Berkeley, California 94720, USA.

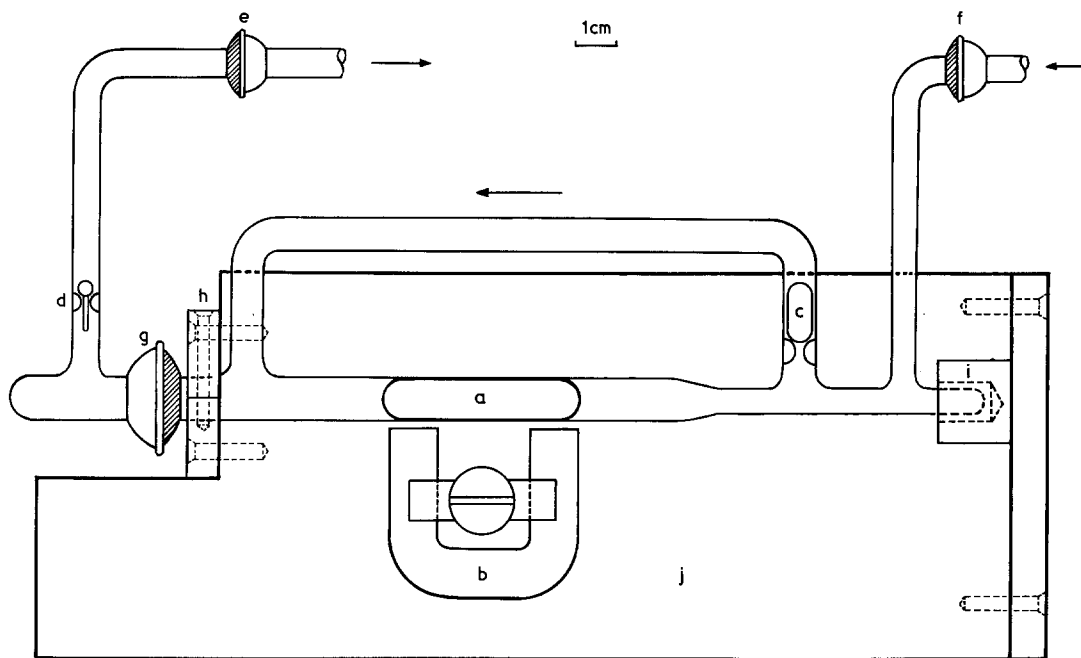

Fig. 1. Constant volume gas pump. a, Teflon coated magnetic stirring bar (5 cm long, 1 cm diameter). b, Horseshoe permanent magnet. c, Hollow gas valve (6 mm o.d., 1 cm long) that rests on a glass constriction (3 mm i.d., 8 mm o.d.). d, Solid glass valve (ball diameter 4 mm; stem length 10 mm) that rests on a glass constriction (3 mm i.d., 6 mm o.d.). e, f, Spherical ground glass joints ($\nabla 12/5$), gas outlet and gas inlet of the pump, respectively. g, Spherical joint ($\nabla 18/9$) that allows the removal of the embolus from its jacket. h, i, Supports that hold the pump in position, made of Plexiglas and wood, respectively. j, Rear part of an aluminium box containing an electrical motor used to move the magnet b. The shaded parts at the spherical joints show the Torr-Seal used to insure vacuum isolation of the system. All tubes are made from Pyrex glass.

displacement to the right, valve c falls down because the pressure difference across the valve is no longer sufficient to force it up. Because a relatively large volume is left between the pump and the cell, and because the valve controlling the gas exit from the cell is maintained in a slightly open position, the gas does not go back to the cell when the embolus moves to the right. When the embolus moves towards the left (maximum displacement ca. 4 cm), the pressure to the left of the embolus increases sufficiently to lift the valve d, thus allowing the gas to circulate. During this operation valve c closes because pressure above it is greater than that below it. Simultaneously with the embolus displacement that creates the reduced pressure to the right, gas flows from the cell to the pump through the tube placed to the right of valve c, as indicated by the arrow in the front of the ball-socket joint of this tube. The continuous repetition of the entire cycle circulates the gas in the direction shown by the arrows. Valves c and d, and their respective seats, have been ground one upon

the other to form matched units thus making a very effective sealing. The size of the bubbles and the bubbling speed through the solution are controlled by adjusting the gas inlet and outlet stopcocks of the electrochemical cell.

Fig. 2 shows the diagram of the mechanical assembly used to operate the gas pump. The wheel is rotated with an electrical motor (60 cpm). The purpose of the whole assembly is to convert the rotary motion of the wheel to a horizontal translational motion of the permanent magnet which in turn moves the magnetic bar in the pump.

Although the pump is presently used for re-circulating gas, it may be used in the conventional manner for pumping gas into a collection flask by merely attaching the assembly to the pump exit (joint e). Two working models of the pump exist and have been in trouble-free operation for nearly 2 years. The pumps have run continuously for periods of up to 1 week without any failure or missing of pumping cycles. The quantitative performance characteristics of the pump depend

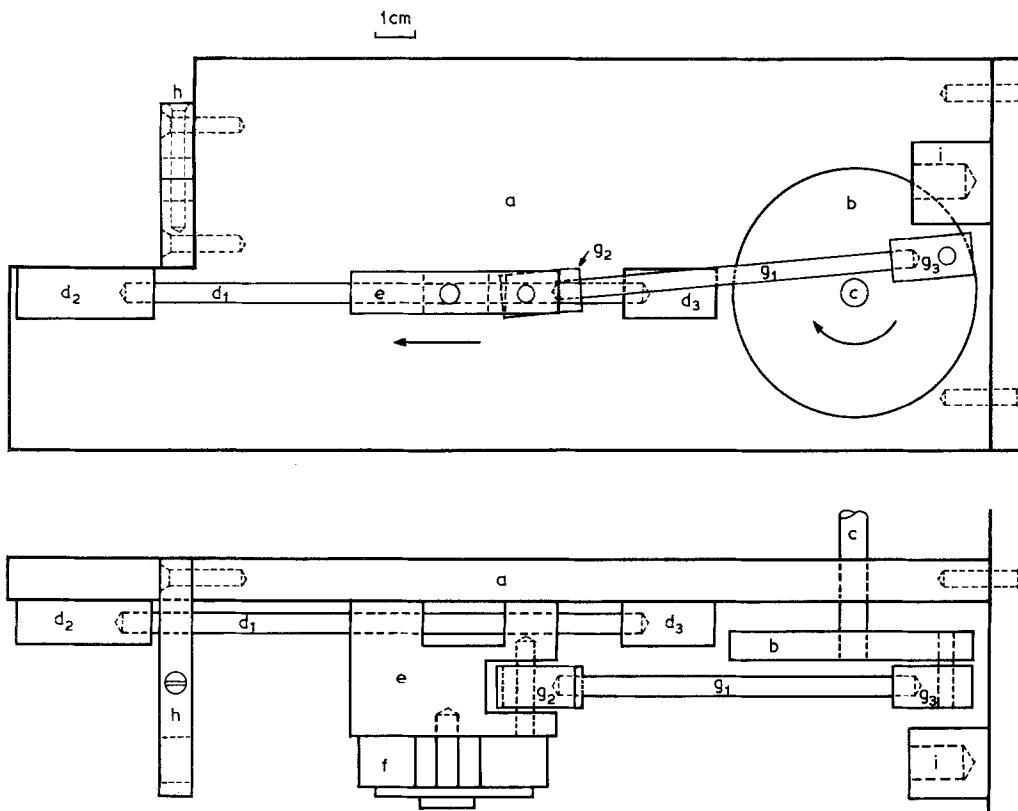

Fig. 2. Mechanical assembly to operate the gas pump. The diagram shows a front view (top of the diagram) and a top view (bottom of the diagram) of the mechanical assembly used to move the gas pump. Its parts are as follows. a, Same as j of Fig. 1. b, Wheel, rotates at 60 cpm. c, Shaft of the electrical motor (60 cpm) to which the wheel is attached. d_1 , Solid rod. d_2 , d_3 , Solid, hexagonal-base cylinders that are fixed to the platform a, and hold the rod d in position. e, Metallic part, slides on rod d_1 horizontally. f, Horseshoe permanent magnet (shown as b at Fig. 1), is attached to part e (not shown at the front view diagram for simplicity). g_1 , Solid cylinder rod. g_2 , g_3 , Connectors attached to part e and the wheel b, respectively, by means of small greased stainless-steel rods (shown as small circles at the front-view diagram and as parallel dash lines at the top-view diagram). The whole g assembly (g_1 , g_2 , g_3) transmits the circular motion of the wheel (b) to part e that moves horizontally (arrows show the motion direction of platform e, and therefore of the magnet b, when the wheel rotates in a clockwise direction). h, and i, Same as h and i of Fig. 1. All parts are made of bronze, except part a which is made of aluminium, and rods d_1 and g_1 which are made of steel.

on the total operating pressure, the size and closeness of fit of the embolus, the distance of travel of the embolus, and the frequency with which the embolus is moved in the tube. For the particular pump dimensions described here, the pump is capable of delivering gas through at least a 20 cm hydrostatic head.

Acknowledgement

Acknowledgement is made to the Donors of the

Petroleum Research Fund, administered by the American Chemical Society for the support of this research.

Reference

- [1] L. F. Silvester and P. A. Rock, *J. Electrochem. Soc.* **121** (1974) 251.